

# RN-1

## Zone Guide

Draft zones are proposed and have not yet been adopted by the City of Portland

The draft RN-1 zone combines the existing R-1 and R-2 zones from the current land use code into a new residential neighborhood zone, intended to accommodate the lowest intensity of residential development within the City of Portland. This zone guide will highlight some of the key differences between the current R-1 and R-2 zones and the draft RN-1, to help you get a better understanding of proposed changes.





[Click here to view a map of current zones on the City's zoning map viewer.](#)

Draft

## RN-1 Purpose Statement

To provide for residential development predominantly characterized by a mixture of single-family and two-family homes on large lots of at least 10,000 square feet. Select nonresidential uses may also be permitted in the RN-1 zone.

## What uses would be allowed?

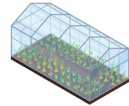
R-1 + R-2 zones	Current	RN-1 zone	Draft
 Single-family	<b>Other uses include:</b> <ul style="list-style-type: none"><li>• Group homes</li><li>• Child care centers</li><li>• Schools</li><li>• Places of assembly</li><li>• Agriculture</li><li>• Parks + Open Spaces</li><li>• Intermediate care facilities</li><li>• Long-term care facilities</li><li>• Solar energy systems</li><li>• Accessory dwelling units</li></ul>	 Single-family	 Neighborhood nonresidential reuse
		 Two-family	 Market Garden
			<b>Other uses include:</b> <ul style="list-style-type: none"><li>• Group homes</li><li>• Child care centers</li><li>• Schools</li><li>• Places of assembly</li><li>• Agriculture</li><li>• Parks + Open Spaces</li><li>• Residential care facilities</li><li>• Solar energy systems</li><li>• Accessory dwelling units</li></ul>

## How have dimensional standards been changed?

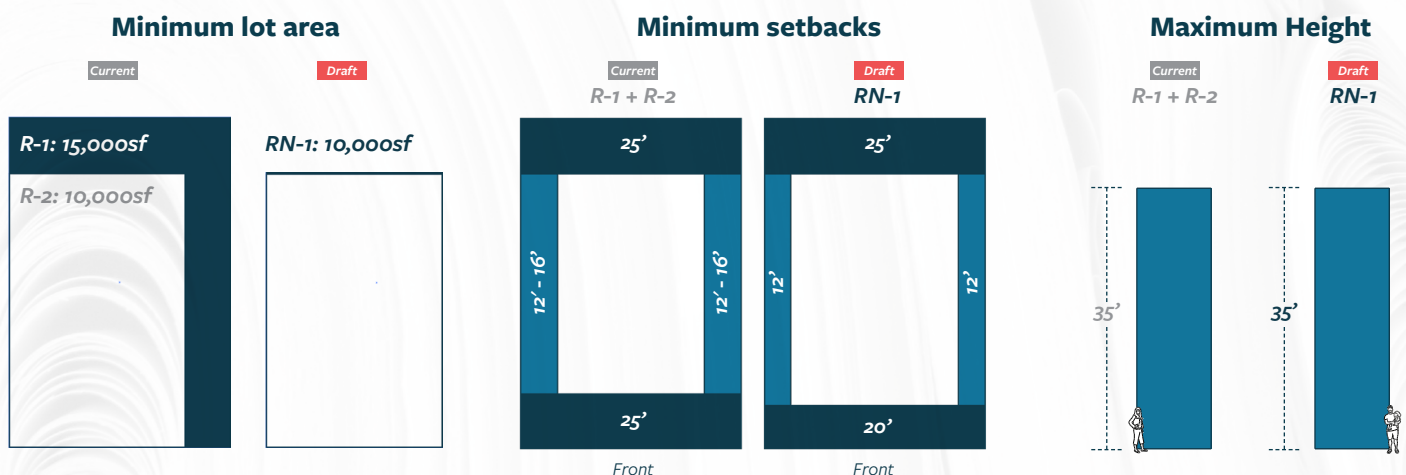

# RN-2

## Zone Guide

Draft zones are proposed and have not yet been adopted by the City of Portland

The draft RN-2 zone would replace the current R-3 zone. The RN-2 zone is intended to accommodate residential development on lots of at least 6,500 square feet within the City of Portland. This zone guide will highlight some of the key differences between the current R-3 zone and the draft RN-2 zone, to help you get a better understanding of proposed changes.





[Click here to view a map of current zones on the City's zoning map viewer.](#)

Draft

### RN-2 Purpose Statement

To provide for residential development predominantly characterized by a mixture of single-family and two-family homes on lots of at least 6,500 square feet. Conversion of existing nonresidential structures to multi-family dwellings is also permitted within the RN-2 zone, subject to standards encouraging compatibility and context sensitivity to ensure the stability of established residential neighborhoods. Select nonresidential uses may also be permitted in the RN-2 zone.

### What uses would be allowed?

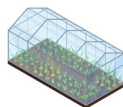
R-3 zone	Current	RN-2 zone	Draft
 Single-family	<p><b>Other uses include:</b></p> <ul style="list-style-type: none"><li>• Group homes</li><li>• Child care centers</li><li>• Schools</li><li>• Places of assembly</li><li>• Parks + Open Spaces</li><li>• Intermediate care facilities</li><li>• Long-term care facilities</li><li>• Solar energy systems</li><li>• Off-street parking</li><li>• Accessory dwelling units</li><li>• PRUDs</li></ul>	 Single-family	<p><b>Other uses include:</b></p> <ul style="list-style-type: none"><li>• Group homes</li><li>• Child care centers</li><li>• Schools</li><li>• Places of assembly</li><li>• Parks + Open Spaces</li><li>• Residential care facilities</li><li>• Solar energy systems</li><li>• Accessory dwelling units</li></ul>
 Multi-family (Existing nonresidential structures only)		 Two-family	
		 Multi-family (Existing nonresidential structures only)	 Market Garden

### How have dimensional standards been changed?

#### Minimum lot area

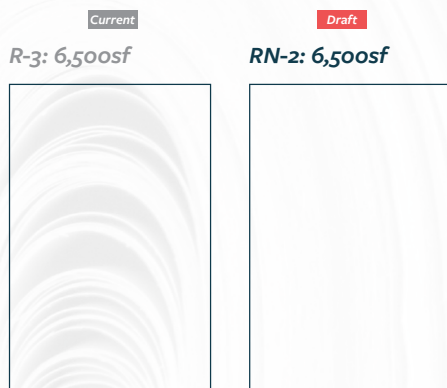

#### Minimum setbacks

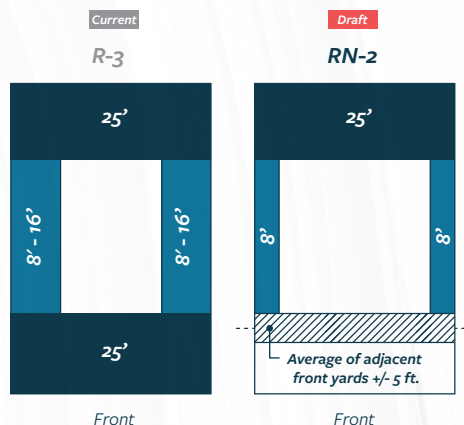

#### Maximum Height

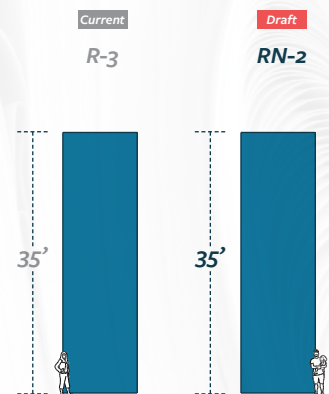

# RN-3 Zone Guide

Draft zones are proposed and have not yet been adopted by the City of Portland

The draft RN-3 would take the place of the current R-4 zone. The RN-3 zone is intended to accommodate a mix of dwelling types on lots of at least 6,000 square feet within the Western Promenade neighborhood. This zone guide will highlight some of the key differences between the the current R-4 zone and the draft RN-3 zone, to help you get a better understanding of proposed changes.









[Click here to view a map of current zones on the City's zoning map viewer.](#)

Draft



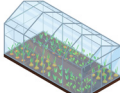

## RN-3 Purpose Statement

To provide for a residential neighborhood environment that acknowledges the unique character of the Western Promenade while accommodating a mixture of single-family, two-family, three-family, and four-family dwellings on lots of at least 6,000 square feet. Construction of new multi-family dwellings at moderate densities is allowed, as-is conversion of existing structures to multi-family dwellings, subject to standards encouraging compatibility and context sensitivity to ensure the stability of established residential neighborhoods. Select nonresidential uses may also be permitted in the RN-3 zone.

## What uses would be allowed?

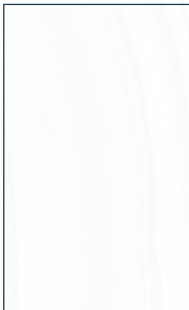
R-4 zone	Current	RN-3 zone	Draft
 Single-family	<p><b>Other uses include:</b></p> <ul style="list-style-type: none"> <li>• Group homes</li> <li>• Child care centers</li> <li>• Schools</li> <li>• Places of assembly</li> <li>• Parks + Open Spaces</li> <li>• Solar energy systems</li> <li>• Off-street parking</li> <li>• Accessory dwelling units</li> </ul>	 Single-family	 Multi-family
 Two-family		 Two-family	 Neighborhood nonresidential reuse
 Multiplex		 Three-family + four-family	 Market Garden

## How have dimensional standards been changed?

Minimum lot area		Minimum setbacks		Maximum Height	
Current	Draft	Current	Draft	Current	Draft
R-4: 6,000sf	RN-3: 6,000sf	R-4	RN-3	R-4	RN-3
					



# RN-4

## Zone Guide

Draft zones are proposed and have not yet been adopted by the City of Portland

The draft RN-4 zone would replace the current R-5 zone, and is intended to accommodate a mix of dwelling types on lots of at least 5,000 square feet within the City of Portland. This zone guide will highlight some of the key differences between the current R-5 zone and the draft RN-4 zone, to help you get a better understanding of proposed changes.

[Click here to view a map of current zones on the City's zoning map viewer.](#)

Draft

### RN-4 Purpose Statement

To provide for a residential neighborhood environment predominantly characterized by a mixture of single-family, two-family, three-family, and four-family dwellings on lots of at least 5,000 square feet. Conversion of existing nonresidential structures to multi-family dwellings is also permitted within the RN-4 zone, subject to standards encouraging compatibility and context sensitivity to ensure the stability of established residential neighborhoods. Select nonresidential uses may also be permitted in the RN-4 zone.

### What uses would be allowed?

**R-5 zone** Current

**Other uses include:**

- Group homes
- Child care centers
- Schools
- Places of assembly
- Parks + open spaces
- Solar energy systems
- Hospitals
- Lodging houses
- Intermediate care facilities
- Long-term care facilities
- Off-street parking
- Accessory dwelling units
- PRUDs

**RN-4 zone** Draft

**Other uses include:**

- Group homes
- Child care centers
- Schools
- Places of assembly
- Parks + Open Spaces
- Residential care facilities
- Solar energy systems
- Accessory dwelling units

### How have dimensional standards been changed?

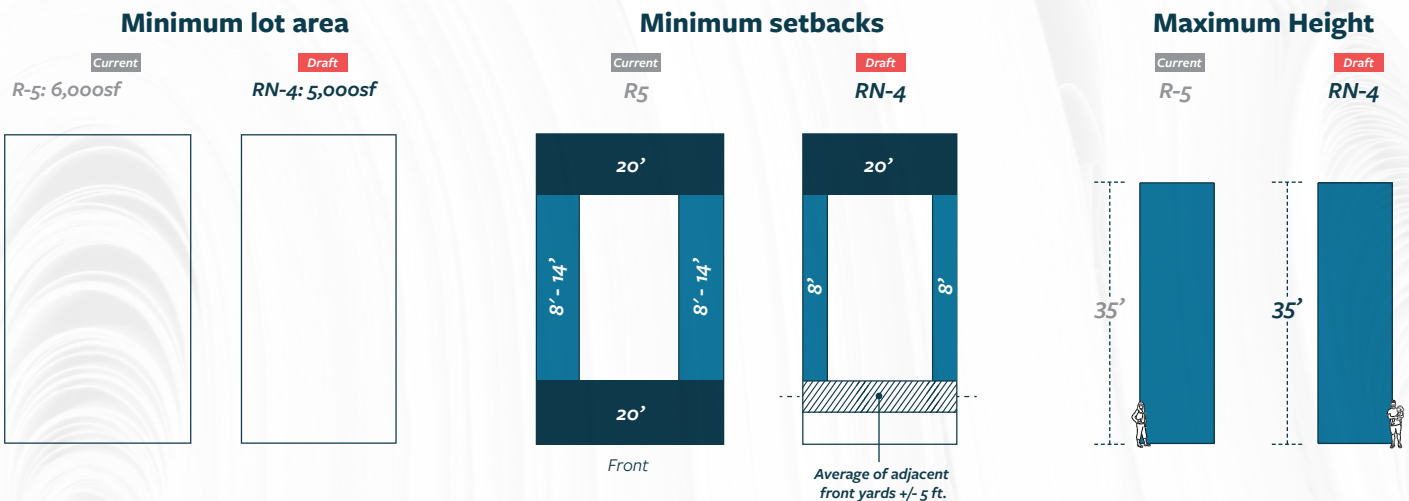



# RN-5 Zone Guide

Draft zones are proposed and have not yet been adopted by the City of Portland

The draft RN-5 zone is designed to replace the current R-6 zone, and is intended to accommodate a broad range of residential development within the City of Portland. This zone guide will highlight some of the key differences between the current R-6 and the draft RN-5 zone, to help you get a better understanding of proposed changes.

[Click here to view a map of current zones on the City's zoning map viewer.](#)

Draft

## RN-5 Purpose Statement

To provide areas of the city, on the peninsula and in select off-peninsula locations in alignment with major public transportation routes and near service areas, for a residential neighborhood environment of mixed residential dwelling types. The RN-5 zone permits a broad range of housing options to accommodate the diverse needs and preferences of Portland's residents and households, including single-family, two-family, three-family, and four-family homes on lots of at least 2,000 square feet, as well as townhouse and multi-family dwellings at a range of densities. Select nonresidential uses may also be permitted in the RN-5 zone.

## What uses would be allowed?

R-6 zone
Current



Single-family



Multi-family



Two-family

**Other uses include:**

- Group homes
- Child care centers
- Schools
- Places of assembly
- Parks + open spaces
- Solar energy systems
- Hospitals
- Lodging houses
- Intermediate care facilities
- Long-term care facilities
- Bed and breakfasts
- General offices
- Hostels
- Off-street parking
- Accessory dwelling units

RN-5 zone
Draft



Single-family



Townhouse



Two-family



Multi-family



Three-family +  
four-family



Neighborhood  
nonresidential reuse

**Other uses include:**

- Market gardens
- Group homes
- Child care centers
- Schools
- Places of assembly
- Parks + Open Spaces
- Residential care facilities
- Solar energy systems
- Lodging houses
- Bed and breakfasts
- Hostels
- Accessory dwelling units

## How have dimensional standards been changed?

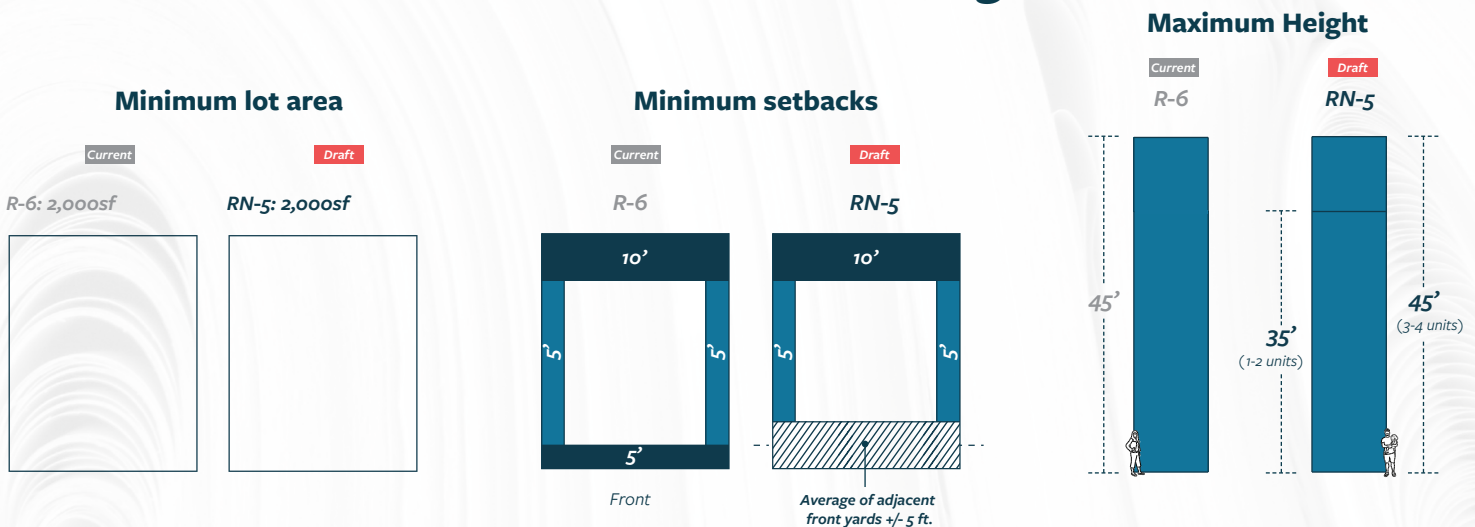

# RN-6

## Zone Guide

Draft zones are proposed and have not yet been adopted by the City of Portland

The draft RN-6 zone combines the current R-5a and R-6a zones into a new residential neighborhood zone, intended to accommodate relatively high density residential development on large lots within the City of Portland. This zone guide will highlight some of the key differences between current R-5a and R-6a zones and the draft RN-6 zone, to help you get a better understanding of proposed changes.

[Click here to view a map of current zones on the City's zoning map viewer.](#)

Draft

### RN-6 Purpose Statement

To accommodate existing areas of the city characterized by a residential neighborhood environment of multi-family dwellings at relatively high density, exhibiting a pattern of larger lots and setbacks, as well as generally taller building heights. Select nonresidential uses may also be permitted in the RN-6 zone.

### What uses would be allowed?

**R-5a + R-6a zones** **Current**

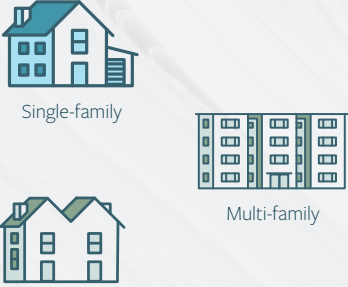

Single-family

Multi-family

Two-family

**Other uses include:**

- Group homes
- Congregate care facilities
- Child care centers
- Schools
- Places of assembly
- Parks + open spaces
- Solar energy systems
- Hospitals
- Intermediate care facilities
- Long-term care facilities
- Lodging houses
- Bed and breakfasts
- Hostels
- General offices
- Off-street parking
- Accessory dwelling units
- PRUDs

**RN-6 zone** **Draft**

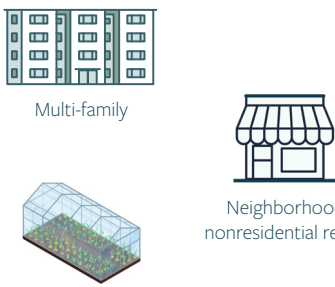

Multi-family

Neighborhood nonresidential reuse

Market Garden

**Other uses include:**

- Market gardens
- Group homes
- Child care centers
- Schools
- Places of assembly
- Parks + Open Spaces
- Residential care facilities
- Solar energy systems
- Lodging houses
- Bed and breakfasts
- Hostels
- Accessory dwelling units

### How have dimensional standards been changed?

#### Minimum lot area

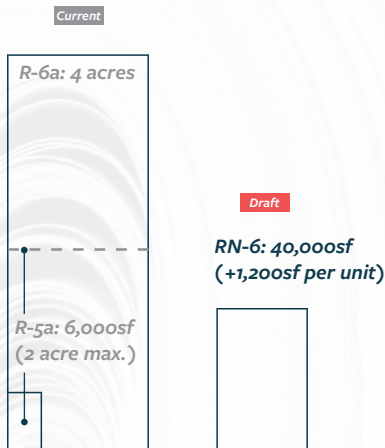

#### Minimum setbacks

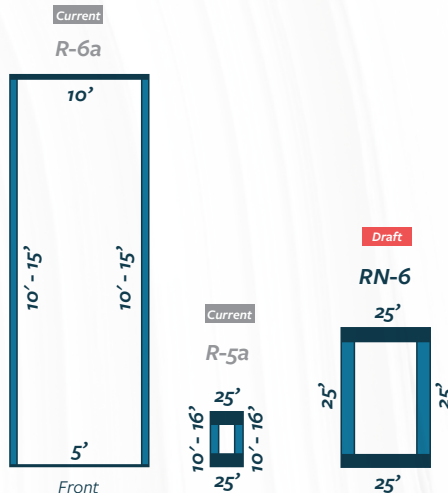

#### Maximum Height

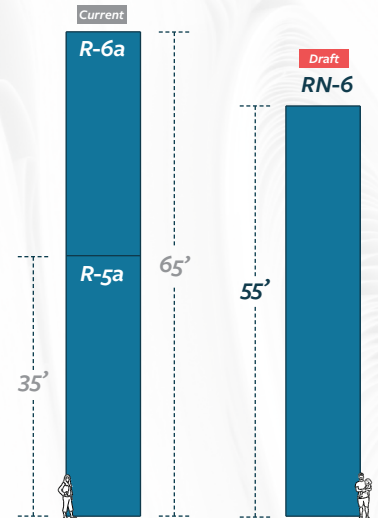

# RN-7 Zone Guide

Draft zones are proposed and have not yet been adopted by the City of Portland

The draft RN-7 zone transitions the current R-7 overlay zone into a new residential neighborhood zone, intended to accommodate a dense residential neighborhood environment, predominantly found on the peninsula. This zone guide will highlight some of the key differences between the current R-7 overlay zone and the draft RN-7 zone, to help you get a better understanding of proposed changes.

[Click here to view a map of current zones on the City's zoning map viewer.](#)

Draft

## RN-7 Purpose Statement

To provide areas of the city, predominantly on the peninsula, for a dense residential neighborhood environment of townhouse and multi-family dwellings. Select nonresidential uses may also be permitted in the RN-7 zone.

## What uses would be allowed?

**R-7 overlay zone** **Current**

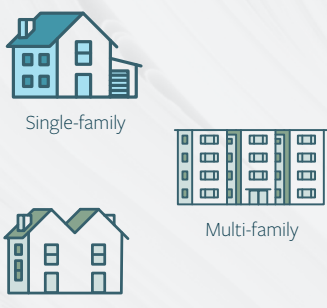

Single-family  
Two-family  
Multi-family

**Other uses include:**

- Group homes
- Child care centers
- Schools
- Places of assembly
- Parks + open spaces
- Solar energy systems
- Hospitals
- Lodging houses
- Intermediate care facilities
- Long-term care facilities
- Bed and breakfasts
- General offices
- Hostels
- Off-street parking
- Accessory dwelling units

**RN-7 zone** **Draft**



Townhouse  
Market Garden  
Multi-family  
Neighborhood nonresidential reuse

**Other uses include:**

- Market gardens
- Group homes
- Child care centers
- Schools
- Places of assembly
- Parks + Open Spaces
- Residential care facilities
- Solar energy systems
- Lodging houses
- Bed and breakfasts
- Hostels
- Accessory dwelling units

## How have dimensional standards been changed?

### Minimum lot area

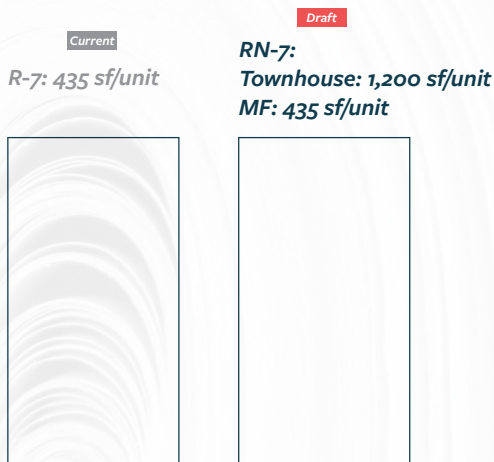

### Minimum setbacks



### Maximum Height

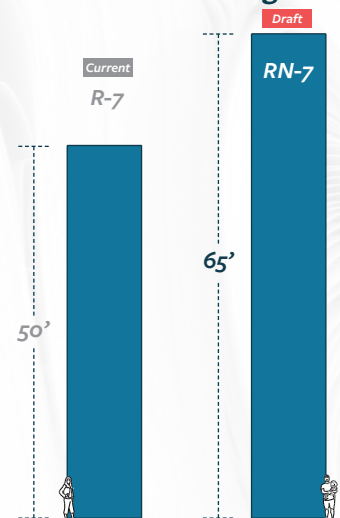



# B-1

## Zone Guide

Draft zones are proposed and have not yet been adopted by the City of Portland

Draft

### B-1 Purpose Statement

To provide limited areas that support a small scale, pedestrian-friendly, mixed-use environment, allowing residents access to daily shopping and service needs within walking distance of nearby established residential neighborhoods. The B-1 zone provides for a mixture of commercial and service uses, closely integrated with – and complimentary to – the surrounding residential neighborhood fabric to support the concept of a complete neighborhood. Suitable locations for this zone may include street intersections and arterial streets with existing or proposed traditional neighborhood retail and service uses.









Recode proposes some important updates to the B-1 zone within the current land use code, including consolidation with the B-1b zone.

These changes are intended to promote neighborhood-scale mixed-use nodes and encourage new development in the B-1 zone. This zone guide will highlight some of the key differences between the current B-1 and the draft B-1 zones, to help you get a better understanding of proposed changes.

[Click here to view a map of current zones on the City's zoning map viewer.](#)

### What uses would be allowed?

#### Residential uses

B-1 zone	Current	B-1 zone	Draft
 Single-family		 Single-family	 Two-family
 Two-family		 Three + four-family	 Townhouse
 Multi-family		 Multi-family	

#### Nonresidential uses

Use	Current B-1	Draft B-1
Bed + Breakfasts	●	●
Clinics	●	
Low-impact industrial		●
Market gardens		●
Restaurants	●	●
Retail	●	●
Specialty food service		●
Studios for artists + craftspeople	●	●

*Please note: This is a sample comparison of uses, and not the full set of uses allowed in these zones. It is intended for informational purposes only.*

### How have dimensional standards been changed?

#### Lot area + frontage

	Current B-1	Draft B-1
<b>Lot area (min.)</b>		--
School	20,000 SF	--
Place of assembly	10,000 SF	--
Per dwelling unit		--
On-peninsula	435 SF	--
Off-peninsula	1,000 SF	--
<b>Street frontage (min.)</b>	20 ft.	20 ft.

#### Setbacks (principal structures)

	Current B-1	Draft B-1
<b>Front setback</b>	10 ft. (max.) or average front yard depth of nearest developed lot if <10 ft.	0-5 ft. build-to zone
<b>Rear setback</b>	None, except 10 ft. if abutting a residential zone	
<b>Side setback</b>	None, except 5 ft. if abutting a residential zone	

#### Structure Height (max.)

	Current B-1	Draft B-1
<b>On-Peninsula:</b> 45 ft., except 50 ft. along Congress Street if commercial first floor and residential above		50 ft.
<b>Off-Peninsula:</b> 35 ft.		

Current B-1  
(Off-peninsula)

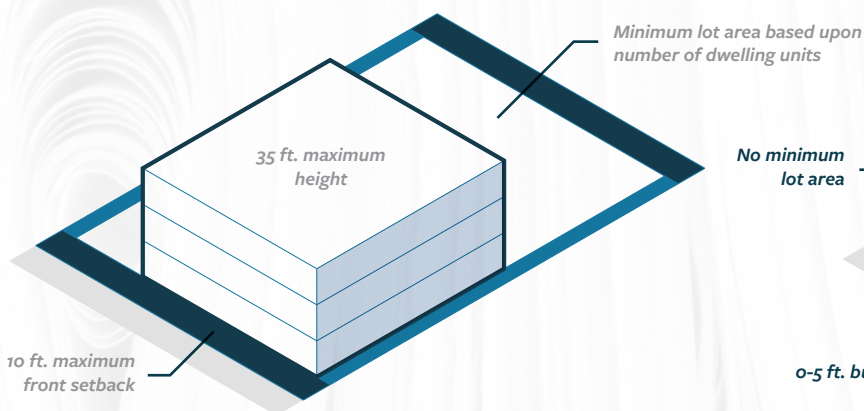

Draft B-1  
(Off-peninsula)

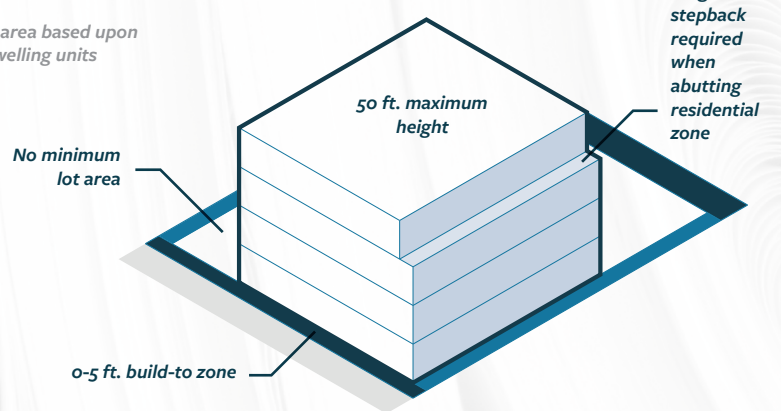

*Please note: This sheet presents key changes, and not the entirety of change from the current Code to the Draft Code. It is intended for informational purposes only.*

# B-2 + B-2b

## Zone Guide

Draft zones are proposed and have not yet been adopted by the City of Portland

The draft B-2 and B-2b zones contain some important updates, including consolidation of the B-2c zone within the current land use code, updates to permitted uses in the zones, and updates to some key dimensional standards. This zone guide will highlight some of the key differences between the current B-2 zones and the draft B-2 zones, to help you get a better understanding of proposed changes.

[Click here to view a map of current zones on the City's zoning map viewer.](#)

Draft

### Purpose Statements

**B-2:** To provide locations for a mixture of commercial, service, and residential uses in a comfortable pedestrian environment that is easily accessible and well-connected to surrounding neighborhoods. Such a mixture may serve the daily needs of nearby residents within walking distance, as well as surrounding neighborhoods via multiple modes of transportation. The zone provides a broad range of goods and services with a mixture of large and small buildings, such as grocery stores, shops and services located in shopping centers and along arterial streets. The B-2 zone's multi-modal orientation accommodates all modes of transportation, and the standards of the zone require that development relate to surrounding neighborhoods by design, orientation, and circulation patterns. The zone encourages mixed-use development, and provides locations for moderate to high-density housing in urban neighborhoods along arterials.

**B-2b:** To provide neighborhood and community retail, business and service establishments that are oriented to and built close to the street. The B-2b zone is suitable in areas where a more compact urban development pattern exists or where a neighborhood-compatible commercial district is established which exhibits a pedestrian scale and character. Such locations may include the peninsula and other arterials and intersections with an existing urban or neighborhood-oriented building pattern. The B-2b zone encourages mixed-use development, and provides locations for moderate to high-density housing in urban neighborhoods along arterials.

### What uses would be allowed?

#### Residential uses

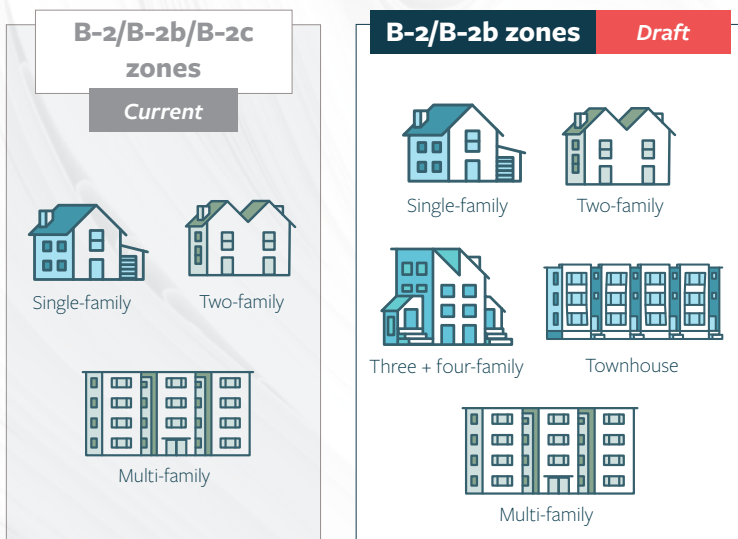

#### Nonresidential uses

● - Permitted ○ - Conditional

Use	Current B-2/b/c	Draft B-2/b
Bed + Breakfasts	●	●
Clinics	●	●
Low-impact industrial	●	●
Market gardens		●
Restaurants	●	●
Retail	●	●
Specialty food service		●
Warehousing + distribution	○	

*Please note: This is a sample comparison of uses, and not the full set of uses allowed in these zones. It is intended for informational purposes only.*

### How have dimensional standards been changed?

#### Lot area + frontage

	Current B-2/b/c	Draft B-2/b
<b>Lot area (min.)</b>	--	--
Per dwelling unit	--	--
On-peninsula	435 SF	--
Off-peninsula	1,000 SF / 435 SF with active frontage	--
<b>Street frontage (min.)</b>	20 ft.	--

#### Setbacks (principal structures)

	Current B-2/b/c	Draft B-2/b
<b>Front setback</b>	10 ft. (max.)	0-10 ft. build-to zone
<b>Rear setback</b>	10 ft. (min.)	None, except 10 ft. if abutting a residential zone
<b>Side setback</b>	None	None, except 5 ft. if abutting a residential zone

#### Structure Height (max.)

Current B-2/b/c	Draft B-2/b
45 ft.   50 ft. if commercial first floor. 65 ft. in B-2 and B-2c on lots > 5 ac. if side and rear setbacks are increased by 1 ft. for each ft. of height over 45 ft.	65 ft or as shown on the <a href="#">Portland Height Map</a> , except 50ft for any portion of a structure within 25 ft. of RN-1, RN-2, RN-3, RN-4.

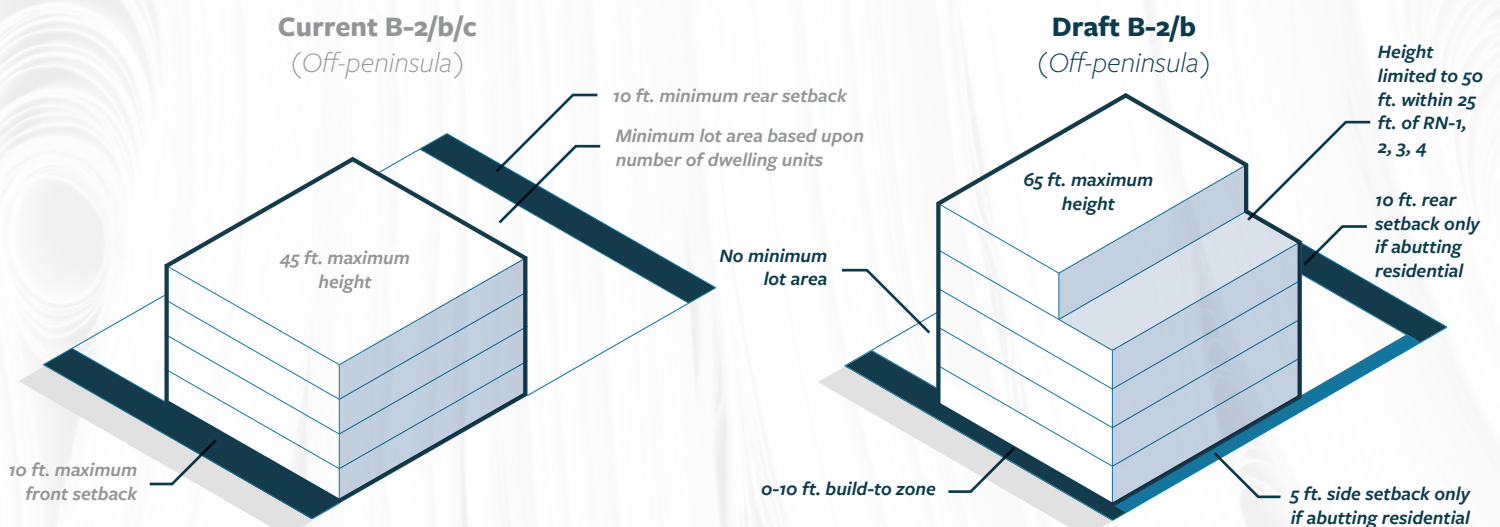



# B-3

## Zone Guide

Draft zones are proposed and have not yet been adopted by the City of Portland

The draft B-3 zone consolidates the current B-3, B-3b, B-3c, and B-7 zones into a new mixed-use zone that serves downtown Portland. These changes simplify the current approach, and seek to encourage new development in the B-3 zone in line with the City's vision for downtown growth. This zone guide will highlight some of the key differences between the current zones and the draft B-3 zone, to help you get a better understanding of proposed changes.

[Click here to view a map of current zones on the City's zoning map viewer.](#)

Draft

### B-3 Purpose Statement

To maintain and enhance the role of the downtown as the business and commercial center of the region, and to enhance and promote the orderly expansion of retail and service businesses downtown, satisfying the related needs of the city's resident, working, and visitor populations. The B-3 zone encourages increased housing opportunities downtown to accommodate Portland's diverse residential population, and supports an active, walkable pedestrian environment through the encouragement of intensive mixed-use activities, enhancement and maintenance of public and private open space, and the enlivenment and increased attractiveness of the street environment.

### What uses would be allowed?

#### Residential uses

**B-3/b/c + B-7 zones**

Current



Single-family



Two-family



Multi-family

**B-3 zone** Draft



Three + four-family



Townhouse



Multi-family

#### Nonresidential uses

● - Permitted    ◐ - Conditional

Use	Current B-3/b/c	Current B-7	Draft B-3
Bed + Breakfasts	●	●	●
Clinics	●	●	●
Low-impact industrial	◐	●	●
Market gardens			●
Restaurants	●	●	●
Retail	●	●	●
Specialty food service			●
Warehousing + distribution	◐	◐	

*Please note: This is a sample comparison of uses, and not the full set of uses allowed in this zone. It is intended for informational purposes only.*

### How have dimensional standards been changed?

#### Lot area + frontage

	Current B-3/b/c, B-7	Draft B-3
<b>Lot area (min.)</b>	--	--
School	--	--
Place of assembly	--	--
Per dwelling unit	--	--
On-peninsula	--	--
Off-peninsula	--	--
<b>Street frontage (min.)</b>	B-3/b/c: 15 ft.	--

#### Setbacks (principal structures)

	Current B-3/b/c	Draft B-3
<b>Front setback</b>	B-3/b/c: 5 ft. (max.)	0-5 ft. build-to zone
	B-7: 10 ft. (max.)	
<b>Rear setback</b>	None	None
<b>Side setback</b>	None	None

#### Structure Height (max.)

Current B-3/b/c, B-7	Draft B-3
See <a href="#">Downtown and Bayside Height Overlay</a> Maps	See <a href="#">City of Portland Height Map</a>



# B-4

## Zone Guide

Draft zones are proposed and have not yet been adopted by the City of Portland

ReCode proposes some important updates to the B-4 zone within the current land use code, including allowing a number of new uses, and refinements to dimensional controls. This zone guide will highlight some of the key differences between the current B-4 and the draft B-4 zones, to help you get a better understanding of proposed changes.

[Click here to view a map of current zones on the City's zoning map viewer.](#)



Draft

### B-4 Purpose Statement

To provide locations in the city for the development and operation of businesses serving a regional or larger market, to provide locations for large-scale commercial uses that require larger land areas to accommodate their operations, and to support moderate to high-density housing. Standards of the B-4 zone acknowledge the need to maintain automobile access while encouraging improvement of the pedestrian environment and accommodating alternative modes of transportation.

### What uses would be allowed?

#### Residential uses

B-4 zone	Current	B-4 zone	Draft
None			Three + four-family
			Townhouse
			Multi-family

#### Nonresidential uses

Use	Current B-4	Draft B-4
Auto, boat, and related dealerships	●	●
Clinics		●
Low-impact industrial	●	●
Market gardens		●
Restaurants	●	●
Retail	●	●
Specialty food service		●
Warehousing + distribution	●	●

*Please note: This is a sample comparison of uses, and not the full set of uses allowed in these zones. It is intended for informational purposes only.*

### How have dimensional standards been changed?

#### Lot area + frontage

	Current B-4	Draft B-4
<b>Lot area (min.)</b>	10,000 SF	10,000 SF
School	10,000 SF	--
Place of assembly	10,000 SF	--
Per dwelling unit	--	--
On-peninsula	--	--
Off-peninsula	--	--
<b>Street frontage (min.)</b>	60 ft.	60 ft.

#### Setbacks (principal structures)

	Current B-4	Draft B-4
<b>Front setback</b>	20 ft. (max.)	0-20 ft. build-to zone
<b>Rear setback</b>	20 ft. (min.)	None, except 20 ft. if abutting a residential zone
<b>Side setback</b>	10 ft. (min.)	None, except 10 ft. if abutting a residential zone

#### Structure Height (max.)

Current B-4	Draft B-4
65 ft.	65 ft.

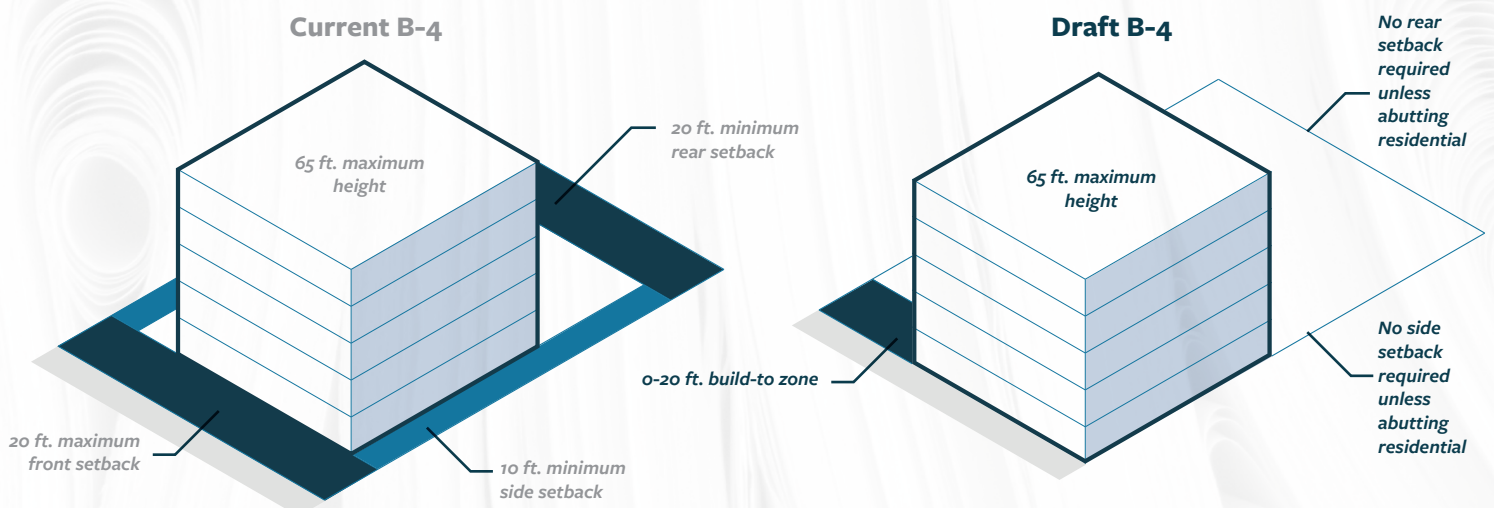

*Please note: This sheet presents key changes, and not the entirety of change from the current Code to the Draft Code. It is intended for informational purposes only.*

# B-5

## Zone Guide

Draft zones are proposed and have not yet been adopted by the City of Portland

Draft







### B-5 Purpose Statement

To provide areas on or proximate to the waterfront, downtown, and the peninsula where a mixture of uses, including marine, industrial, commercial, and residential, is encouraged. The B-5 zone is characterized by larger underdeveloped lots with great potential for dense, clustered, urban mixed-use development and reuse of existing land and buildings. It is anticipated that the dense, mixed-uses of the B-5 zone will rely on a shared infrastructure system, including service alleys, parking lots, public transportation facilities, stormwater management, and driveways.

[Click here to view a map of current zones on the City's zoning map viewer.](#)

### What uses would be allowed?

#### Residential uses

B-5/b zones	Current	B-5 zone	Draft
	Single-family		Three + four-family
	Two-family		Townhouse
	Multi-family		Multi-family

#### Nonresidential uses

● - Permitted ○ - Conditional

Use	Current B-5/b	Draft B-5
Auto service stations	●	
Clinics	●	●
Low-impact industrial	○	●
Market gardens		●
Restaurants	●	●
Retail	●	●
Specialty food service		●
Warehousing + Distribution	●	

*Please note: This is a sample comparison of uses, and not the full set of uses allowed in these zones. It is intended for informational purposes only.*

### How have dimensional standards been changed?

#### Lot area + frontage

	Current B-5/b	Draft B-5
<b>Lot area (min.)</b>	--	--
School	--	--
Place of assembly	--	--
Per dwelling unit	--	--
On-peninsula	--	--
Off-peninsula	--	--
<b>Street frontage (min.)</b>	--	--

#### Setbacks (principal structures)

	Current B-5/b	Draft B-5
<b>Front setback</b>	None, except 10 ft. (max.) in B-5b	0-10 ft. build-to zone
<b>Rear setback</b>	None	None
<b>Side setback</b>	None	None

#### Structure Height (max.)

Current B-5/b	Draft B-5
65 ft., except in B-5b along W. Commercial St. south of Danforth St.5 and 120 ft. on Thompson's Point.	65 ft., or as shown on the <a href="#">City of Portland Height Map</a>



# B-6

## Zone Guide

Draft zones are proposed and have not yet been adopted by the City of Portland

Draft







The draft B-6 zone includes a series of relatively modest updates to the current B-6 zone, focused around introducing some new uses, and ensuring flexibility for new development in the Eastern Waterfront area. This zone guide will highlight some of the differences between the current B-6 and the draft B-6 zones, to help you get a better understanding of proposed changes.

[Click here to view a map of current zones on the City's zoning map viewer.](#)

### B-6 Purpose Statement

To establish a zoning district for the upland portion of the Eastern Waterfront area. The B-6 zone encourages a distinctly urban form through development that emphasizes a quality pedestrian experience, promotes public transit, and demonstrates exemplary urban design. The zone promotes a range of uses to achieve 24-hour urban vitality and shared use of parking infrastructure as recommended in the Eastern Waterfront Master Plan for redevelopment. The B-6 zone promotes a mixed-use development pattern envisioned for urban land on Portland's peninsula.

#### Residential uses

B-6 zone	Current	B-6 zone	Draft
	Single-family		Three + four-family
	Two-family		Townhouse
	Multi-family		Multi-family

### What uses would be allowed?

#### Nonresidential uses

● - Permitted    ◐ - Conditional

Use	Current B-6	Draft B-6
Cultural facilities	●	●
Hotels	●	●
Low-impact industrial	●	●
Market gardens		●
Restaurants	●	●
Retail	●	●
Specialty food service		●
Warehousing + Distribution	◐	

*Please note: This is a sample comparison of uses, and not the full set of uses allowed in these zones. It is intended for informational purposes only.*

### How have dimensional standards been changed?

#### Lot area + frontage

	Current B-6	Draft B-6
<b>Lot area (min.)</b>	--	--
School	--	--
Place of assembly	--	--
Per dwelling unit	--	--
On-peninsula	--	--
Off-peninsula	--	--
<b>Street frontage (min.)</b>	--	--

#### Setbacks (principal structures)

	Current B-6	Draft B-6
<b>Front setback</b>	10 ft. (max.)	0-10 ft. build-to zone
<b>Rear setback</b>	None	None
<b>Side setback</b>	None	None

#### Structure Height (max.)

Current B-6	Draft B-6
65 ft. or as otherwise governed by the B-6 Building Height Overlay Map.	See City of Portland Height Map.



# IR-1

## Zone Guide

Draft zones are proposed and have not yet been adopted by the City of Portland

**There are some proposed changes to the IR-1 zone.** The draft IR-1 zone is intended to accommodate the lowest intensity of residential development on Portland's islands. This zone guide will highlight some of the key differences between the existing IR-1 and the draft IR-1 zone, to help you get a better understanding of proposed changes.

[Click here to view a map of current zones on the City's zoning map viewer.](#)

Draft

## IR-1 Purpose Statement

To provide for a low-intensity environment characterized by single-family, two-family, recreational, and rural uses on Portland's islands. Standards for the IR-1 zone are intended to preserve and protect the rustic character of the islands, to protect groundwater resources and natural and scenic areas, and to permit only low-intensity development in areas lacking adequate public facilities and services.

## What uses would be allowed?

**IR-1 zone** **Current**



Single-family

**Other uses include:**

- Agriculture
- Child care centers
- Schools
- Places of assembly
- Boathouses
- Campgrounds
- Parks and open spaces
- Solar energy systems
- Accessory dwelling units

**IR-1 zone** **Draft**



Single-family



Neighborhood nonresidential reuse

**Other uses include:**

- Agriculture
- Child care centers
- Schools
- Places of assembly
- Boathouses
- Campgrounds
- Parks and open spaces
- Solar energy systems
- Accessory dwelling units

## How have dimensional standards been changed?

### Minimum lot area

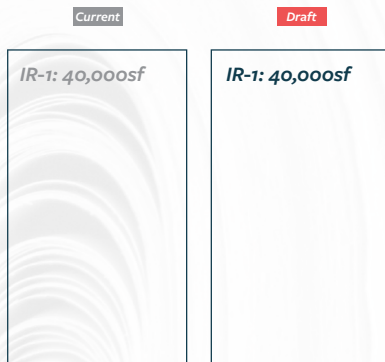

### Minimum setbacks

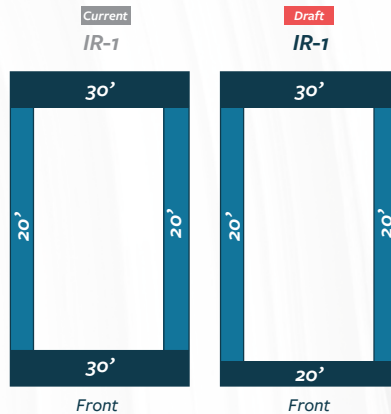

### Maximum Height

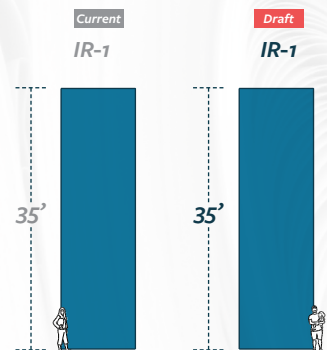

# IR-2

## Zone Guide

Draft zones are proposed and have not yet been adopted by the City of Portland

**There are some proposed changes to the IR-2 zone.** Key changes in the draft IR-2 zone include the creation of “small island lot” provisions for Peaks Island, intended to accommodate and protect the island’s existing development patterns. This zone guide will highlight some of the key differences between the current IR-2 and the proposed IR-2 zone, to help you get a better understanding of proposed changes.

[Click here to view a map of current zones on the City’s zoning map viewer.](#)

Draft

### IR-2 Purpose Statement

To provide for a residential neighborhood environment of single-family and two-family dwellings on Portland’s islands in areas with adequate public services. Expansion or extension of IR-2 zoning should be limited, generally focused toward areas adjacent to existing IR-2 areas, and restricted by such factors as adequacy of access, whether adequate water will be available for private use and for fire protection, whether soils in the area are adequate for subsurface water disposal, or whether public sewers are available.

### What uses would be allowed?

**IR-2 zone** **Current**



Single-family

**Other uses include:**

- Child care centers
- Schools
- Places of assembly
- Lodging houses
- Boathouses
- Parks and open spaces
- Solar energy systems
- Accessory dwelling units

**IR-2 zone** **Draft**



Single-family



Neighborhood nonresidential reuse

**Other uses include:**

- Child care centers
- Schools
- Places of assembly
- Lodging houses
- Boathouses
- Parks and open spaces
- Solar energy systems
- Accessory dwelling units

### How have dimensional standards been changed?

#### Minimum lot area

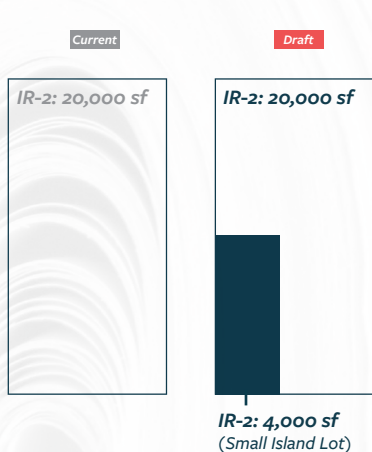

#### Minimum setbacks

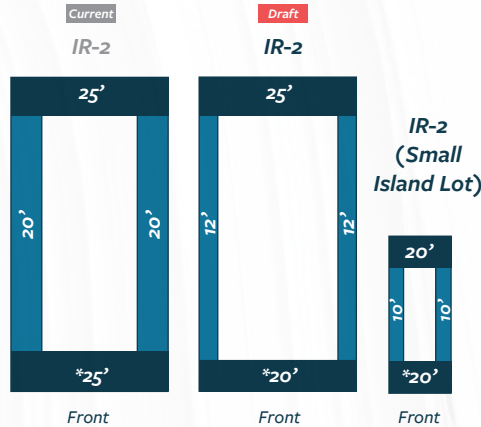

\* Or the average of adjacent front yards, whichever is less.

#### Maximum Height

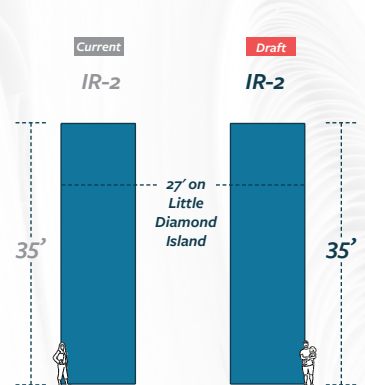

# I-B

## Zone Guide

Draft zones are proposed and have not yet been adopted by the City of Portland

The I-B zone is transitioning to a modified but similar zone of the same name, with changes focusing on expansion of allowed uses to help create complete neighborhoods on Portland's islands. This zone guide will highlight some of the key differences between the current I-B and the draft I-B zone, to help you get a better understanding of proposed changes.







[Click here to view a map of current zones on the City's zoning map viewer.](#)

Draft

### I-B Purpose Statement

To provide limited areas on Portland's islands for the development of a mixture of residential, retail, and service establishments that primarily serve the needs of the local island market area. The I-B zone provides for a mixture of commercial and service uses, closely integrated with – and complimentary to – the surrounding residential neighborhood fabric to support the concept of a complete neighborhood. Standards for the I-B zone may vary by location, dependent upon the availability of public water and sewer resources.

### What uses would be allowed?

I-B zone	Current	I-B zone	Draft
 <p>Single-family</p>	<p><b>Other uses include:</b></p> <ul style="list-style-type: none"> <li>• Auto service stations</li> <li>• Bed and breakfasts</li> <li>• Child care centers</li> <li>• Schools</li> <li>• Places of assembly</li> <li>• Lodging houses</li> <li>• General services</li> <li>• Hotels</li> <li>• Restaurants</li> <li>• Retail</li> <li>• Off-street parking</li> <li>• Boathouses</li> <li>• Parks and open spaces</li> <li>• Solar energy systems</li> </ul>	 <p>Single-family</p>	 <p>Three-family + four-family</p>
 <p>Two-family</p>		 <p>Two-family</p>	 <p>Multi-family</p>
 <p>Multi-family</p>		<p><b>Other uses include:</b></p> <ul style="list-style-type: none"> <li>• Auto service stations</li> <li>• Bed and breakfasts</li> <li>• Child care centers</li> <li>• Schools</li> <li>• Places of assembly</li> <li>• Lodging houses</li> <li>• General offices</li> <li>• General services</li> <li>• Greenhouse/nursery</li> <li>• Hotels</li> <li>• Restaurants</li> <li>• Retail</li> <li>• Specialty food services</li> <li>• Off-street parking</li> <li>• Boathouses</li> <li>• Parks and open spaces</li> <li>• Solar energy systems</li> </ul>	

### How have dimensional standards been changed?

#### Minimum lot area

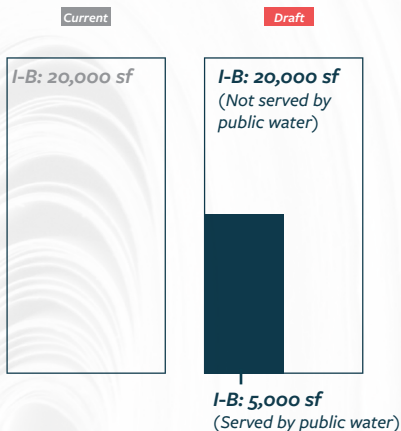

#### Minimum setbacks

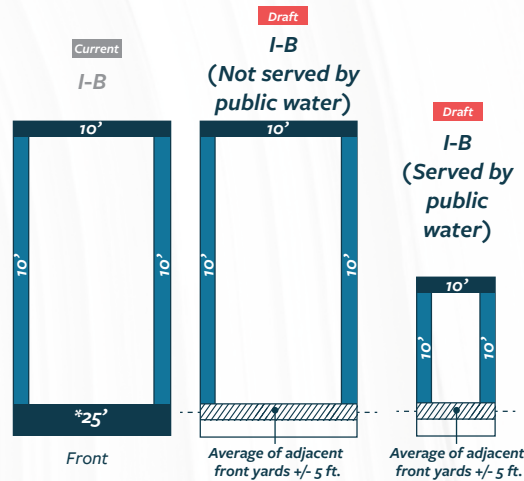

\* Or the average of adjacent front yards, whichever is less.

#### Maximum Height

